

Quick-Start Guide KEYPAD DIMMER

KeypadLinc V2 Dimmer (#2486D)

Need Help? For assistance call your friendly INSTEON support person @ 800-SMARTHOME (800-762-7846)



Quick-Start Guide KEYPAD DIMMER

KeypadLinc™ V2 Dimmer (#2486D)

Your new INSTEON™ Keypad Dimmer allows you to dim and remotely control any light(s) in your home at the touch of a button.

Need Help? For assistance call your friendly INSTEON support person @ 800-SMARTHOME (800-762-7846)

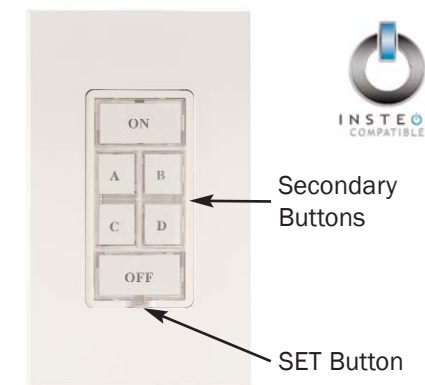

Preparation

Installation should be performed only by a qualified electrician or by a homeowner who is familiar and comfortable with electrical circuitry. If there are any questions, consult an electrician. For setup questions contact Tech Support at Smarthome for guidance.

Tools you will need:

- A standard screwdriver
- A Phillips screwdriver
- A wire cutter/stripper
- Optional: A #1 Phillips screwdriver to change the paddle color (sold separately)
- Optional: A voltage tester to identify wires inside the junction box

Installing Your Keypad Dimmer

- Step 1.** Be sure you have properly installed at least two SignalLinc RF Signal Enhancers (sold separately).
- Step 2.** At the circuit breaker or fuse panel, disconnect the power for all of the circuits in the switch junction box.
- Step 3.** Remove the faceplate from the switch junction box, then unscrew the switch and pull it out from the junction box.
- Step 4.** Disconnect the wires from the switch you are replacing and ensure you have 1/2" of bare wire on the ends.
- Step 5.** If you are installing your Keypad into a **two-way circuit** (where one switch controls the load), follow the diagram below to identify and connect the LINE, LOAD, NEUTRAL, and GROUND wires. If the colors of the wires do not match the diagram, be sure you have identified the wires correctly before connecting them.

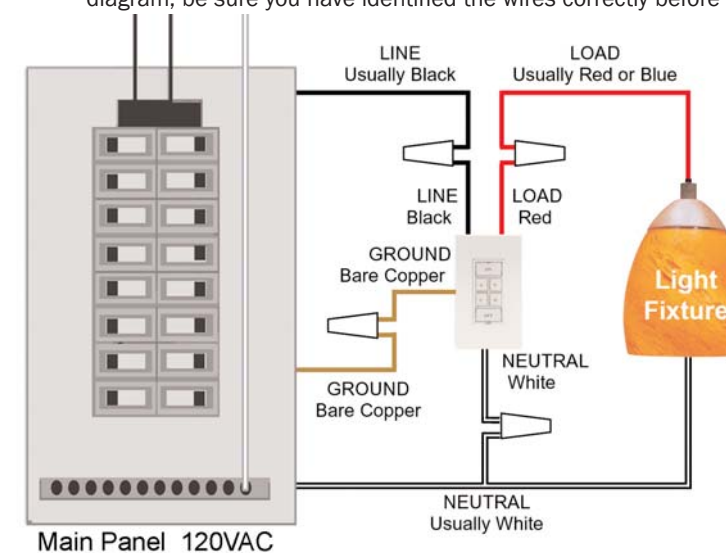

NOTE

The NEUTRAL wire will not normally be connected to the switch you are replacing. If there is no NEUTRAL wire in the junction box, please consult an electrician or call

Smarthome Tech Support
800-SMARTHOME
(800-762-7846)

Optional for X10 Users

To give the Keypad Dimmer an X10 Primary Address

1. Press and hold the **ON button** for 10 seconds until the light flashes - then release.
2. Send the desired X10 Primary Address **THREE times**. The light will flash again.
3. The X10 On-Level and Ramp Rate will be the same as the Local On-Level and Ramp Rate.

To remove an X10 Primary Address from the Keypad Dimmer

1. Press and hold the **ON Button** for 10 seconds until the light flashes - then release.
2. Press and hold the **ON Button again** for 10 seconds until the light flashes again - then release.
3. Send any X10 address **THREE times**. The light will flash again.

Smarthome Limited Warranty

Smarthome warrants to the original consumer of this product that, for a period of two years from the date of purchase, this product will be free from defects in material and workmanship and will perform in substantial conformity to the description of the product in the owner's manual. This warranty shall not apply to defects or errors caused by misuse or neglect.

- Step 6.** If you are installing into a **multi-way circuit** (where more than one switch controls the load), consult the User's Guide.
- Step 7.** Ensure that all wire connectors are firmly attached and that there is no exposed copper except for the GROUND wire.
- Step 8.** Orient your Keypad with the ON button on top, gently place it into the junction box, then screw it into place.
- Step 9.** Turn the circuit breaker back on or re-install the fuse.
- Step 10.** Test that your Keypad is working properly by turning the light on and off by pressing the ON and OFF buttons.
- Step 11.** Reinstall the faceplate.

Quick-Start Guide KEYPAD DIMMER

KeypadLinc V2 Dimmer (#2486D)



Need Help? For assistance call your friendly INSTEON support person @ 800-SMARTHOME (800-762-7846)

Using Your Keypad Dimmer



- Tap the ON button to turn your light on
- Tap the OFF button to turn your light off
- Press and hold the ON button to brighten your light
- Press and hold the OFF button to dim your light
- Double tap the ON button to turn your light on quickly
- Double tap the OFF button to turn your light off quickly

Setting Up Your Keypad Dimmer to Control an INSTEON Device Remotely

Step 1. Press and hold the button you wish to link, either the Keypad Dimmer's ON button (or any of the 4 secondary buttons) for 10 seconds until its LED starts blinking and the light flashes – then release.

Your Keypad Dimmer is now in Linking Mode. You have 4 minutes to complete Step 2.

Step 2. Select the device you would like to control and follow the setup instructions from the table below:

Device	Setup Instructions
 SwitchLinc Dimmer	• Press and hold the SwitchLinc Dimmer's Paddle Top for 10 seconds until the light it controls flashes – then release. The Keypad Dimmer will exit Linking Mode, and its LED will stop blinking.
 Lamp Dimmer	• Press and hold the Lamp Dimmer's SET button for 3 seconds until the lamp it controls flashes – then release. The Keypad Dimmer will exit Linking Mode, and its LED will stop blinking.
 Appliance Module	• Press and hold the Appliance Module's SET button for 3 seconds until its Status LED blinks – then release. The Keypad Dimmer will exit Linking Mode, and its LED will stop blinking.
Other INSTEON-Enabled Devices	See device's Quick-Start Guide or User's Guide

Step 3. Test that the Keypad Dimmer is working properly by turning the light on and off.

Setting Up an INSTEON Controller to Control your Keypad Dimmer Remotely

Step 1. On your INSTEON controller press and hold the ON button of your choice for 10 seconds until the LED begins blinking slowly – then release.

Your INSTEON Controller is now in Linking Mode. You have 4 minutes to complete step 2.

Step 2. Press and hold the Keypad Dimmer's ON button for 10 seconds until the light flashes – then release.

Your INSTEON Controller's LED will stop blinking to indicate successful linking.

Step 3. On your INSTEON Controller press the ON and OFF buttons several times to make sure everything is working properly.

Quick-Start Guide KEYPAD DIMMER

KeypadLinc V2 Dimmer (#2486D)



Need Help? For assistance call your friendly INSTEON support person @ 800-SMARTHOME (800-762-7846)

Using Your Keypad Dimmer's Advanced Features

To unlink a device from the Keypad Dimmer

1. Press and hold the **Button the device is linked to** for 10 seconds until the light flashes - then release.
2. Press and hold the **Button the device is linked to again** for 10 seconds until the light flashes again - then release.
3. On the INSTEON device you wish to unlink, press and hold the **ON button** for 10 seconds or the **SET button** for 3 seconds.

To change the Keypad Dimmer's Local On-Level or Ramp Rate

1. Dim or brighten to the desired **Ramp Rate** (dimmer = slower Ramp Rate).
2. Press the **SET Button TWICE**. The light will flash once. Test by tapping the ON button.
3. Dim or brighten to the desired **On-Level** brightness.
4. Press the **SET Button ONCE**. The light will flash once. Test by tapping the ON button.
5. Don't link Keypad Dimmer for 4 minutes.

To change the Keypad Dimmer's Remote-Controlled On-Level or Ramp Rate

1. Dim or brighten to the desired **On-Level** brightness.
2. Press the **SET Button ONCE**. The light will flash once.
3. Dim or brighten to the desired **Ramp Rate** (dimmer = slower Ramp Rate).
4. Press the **SET Button TWICE**. The light will flash once.
5. Go into **Linking Mode** on the INSTEON Controller that will control this Keypad.
6. Press and hold the Keypad's **ON button** for 10 seconds until the light flashes - then release.
7. The Local Ramp Rate and On-Level will be unchanged.

To factory reset a secondary button on the Keypad Dimmer

1. Pull the **SET Button all the way out** and wait 10 seconds.
2. Push the **SET Button all the way in** while pressing the secondary button you would like reset.
3. The secondary button's LED will turn on.

To change from 6 to 8 buttons (and vice versa)

1. Pull the **SET Button all the way out** and wait 10 seconds.
- To Install 8-button faceplate: Press in **SET Button** while holding in the buttons A and H.
To Install 6-button faceplate: Press in **SET Button** while holding in ON and OFF.

To factory reset your Keypad Dimmer

1. Pull the **SET Button all the way out** and wait 10 seconds.
2. Push the **SET Button all the way in** and hold for 3 seconds - then release.
3. After 3 seconds, the light will turn on fully.

Notes

- Pressing the SET Button after going into Linking Mode will change Linking Mode to Scene Setup (Multi-Link) Mode
- Any button press will exit Linking Mode early

For detailed instructions on how to operate all the features of your Keypad Dimmer, please refer to the User's Guide at <http://www.smarthome.com/2486d.html>