

# DTK932V7

## NETWORK BRIDGE INSTRUCTION MANUAL



## Contents

Warning.....	2	Mounting & Supply Cable Connections .....	5
Features.....	2	Connecting Serial Control Cables.....	6
Important Safeguards.....	2	Troubleshooting.....	7
Internal View.....	3	Specifications.....	8
Applications for the DTK932 .....	4		



### Warning

- TO REDUCE THE RISK OF FIRE OR ELECTRIC SHOCK, DO NOT EXPOSE THIS DEVICE TO RAIN OR MOISTURE.
- DO NOT ENERGISE UNLESS THE FRONT COVER IS IN PLACE.
- THIS DEVICE MUST BE EARTHED.
- INSTALLATION, PROGRAMMING AND MAINTENANCE MUST BE CARRIED OUT BY QUALIFIED PERSONNEL.

## Features

- **Single Phase Supply**  
Simple supply requirement, Single Phase at 0.5A.
- **2 Serial Ports**  
Both serial ports are RS485.
- **Optical Isolation**  
The two halves of the Bridge are linked by an optical isolation barrier rated at 4KV.
- **Programmable Message Passing**  
This device can be programmed to block specific types of message for increased network security.
- **DMX512 Gateway Mode**  
This device can be programmed to convert DyNet to DMX512 transmit, 120 channels.
- **Internal Sequencer**  
The DTK932V7 has powerful sequencing capability, with Tasks able to be started from dry contact closures, Start Task messages, and from any section of a normal network messages, with wildcards available for any byte of the packet. User accessible Ram, and conditional branching are available to the programmer. Programming of the sequencer is via DLight™ PC software. Contact your local agent for details.

## Important Safeguards

**Read Instructions** – We recommend that you read this Instruction Manual prior to commencement of installation. Retain instructions and give to the end user.

**Troubleshooting** - If problems are encountered, read the troubleshooting section on page 11.

**Special Programming** – This device will only operate in basic modes unless programmed via a computer. If programming is required, contact your local agent for details. You should have all terminations made and be able to turn all lighting circuits on and off from control plates *before* the programming engineer arrives at the job.

**Check Connections** – Treat this device as a switchboard that has been shipped. Tighten all screw connections, as vibrations from transport can cause MCB and terminal block screws to become loose.

**Power Sources** – This device should only be operated from the type of supply specified on the front panel. This device *must* be earthed.

**Data Cable** – The recommended cable for connections to the serial port is screened, stranded RS485 data cable with three twisted pairs. Part numbers for various manufacturers are listed on page 6. This cable should be segregated from mains cables by a minimum distance of 300mm. If anticipated cable runs are over 600 metres for serial cables, consult your dealer for advice. Do not cut or terminate live data cables.

**Megger Testing** – Do not megger test any circuitry connected to the control system, as damage to the electronics may result.

**Mounting Location** – This device should be mounted with a minimum clearance of 100mm for all sides, to enable access to the service switches and LEDs. Install in a dry, well-ventilated location. (Refer to page 4 for mounting instructions.)

# Internal View

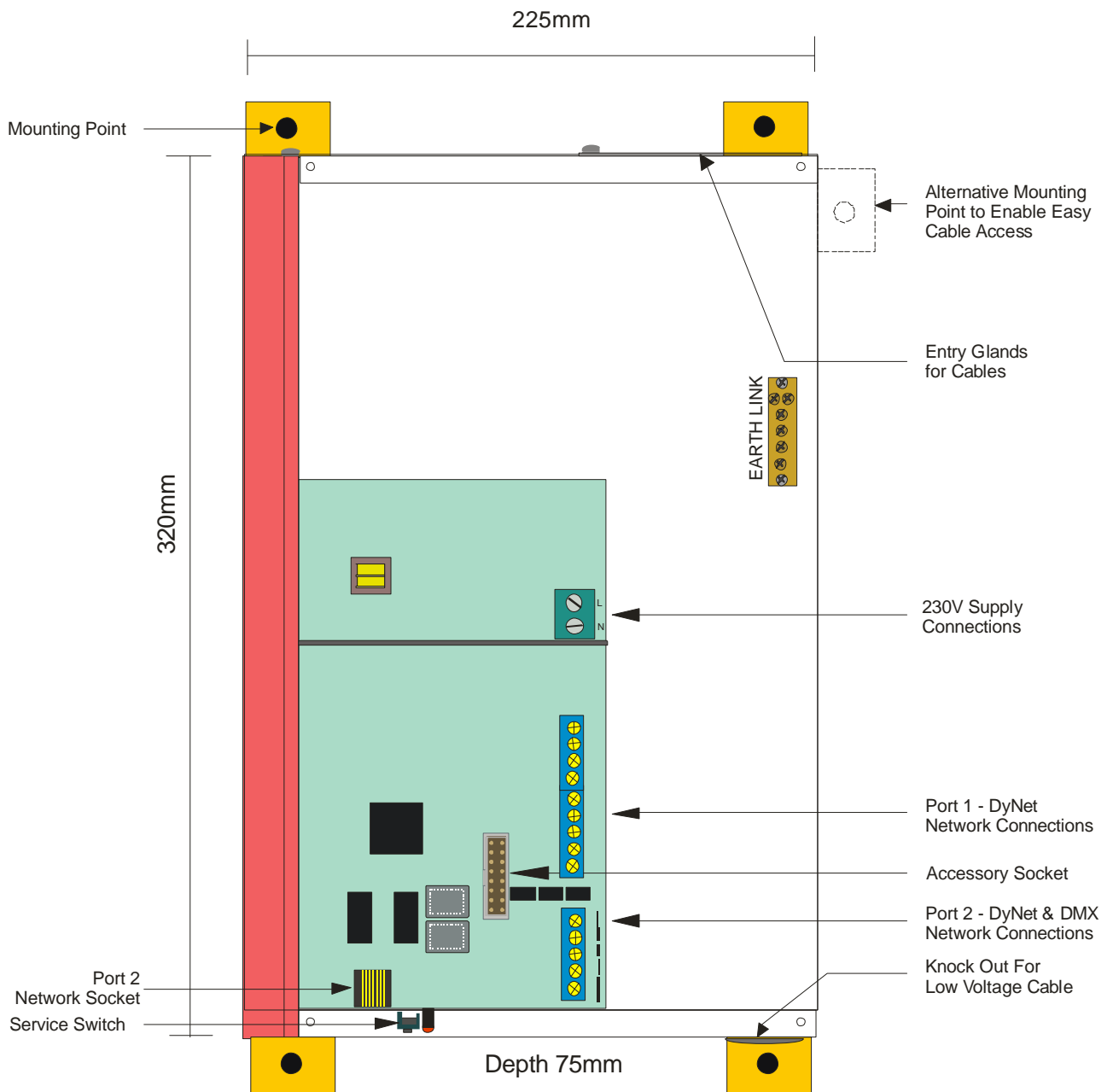

# Applications

The DTK932V7 can be used for several different applications, some of which are described below:

## Implementing Trunk/Spur Topology

This style of topology is used in large installations, where there is one or more data trunk cables that may interconnect DTK932V7s located at different floors or distribution boards. The other port on the DTK932V7 is then connected to a spur that feeds the dimmers and control panels in that locale. The recommended method of connection is to connect the Spur to the Port 1, and the trunk to the Port 2. Some reasons for implementing Trunk/Spur topology include:

**OPTICAL ISOLATION** – A fault on a Spur will be localised to that Spur only, the rest of the system will be unaffected.

**QUANTITY OF NETWORK DEVICES** – A finite number of devices can be connected to a single RS485 data cable. The recommended maximum number of devices is 64. The use of DTK932s gives a maximum of 64 devices per spur, with 64 spurs per trunk, a total of 4096 devices per trunk. There can be as many trunks as required.

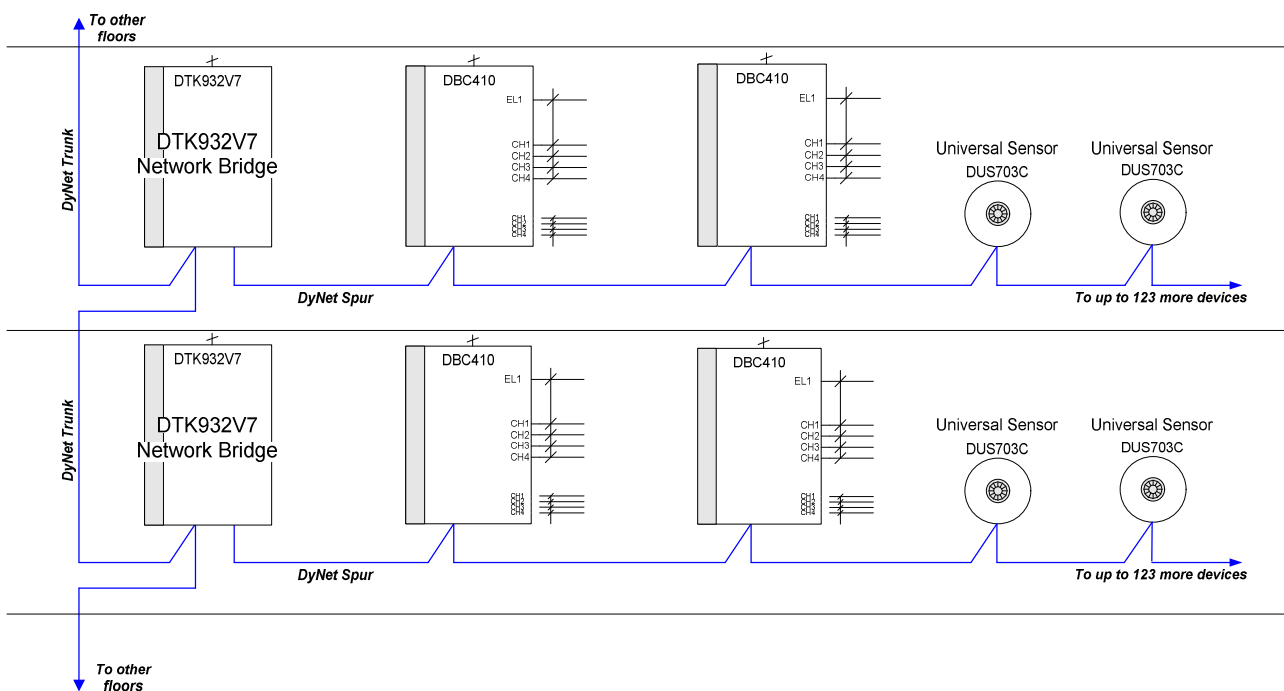

## Interfacing To Other Systems

The DTK932V7 can be used to connect other manufacturers equipment to the Dynalite network. A common example of this is when using AV type touch screens. The DTK932V7 can be programmed to allow only certain types of messages to pass to the lighting control network, which provides an increased level of network security, and guards against potentially detrimental messages from being accidentally sent by the AV system. High level interface to other AV or Building Automation System (BMS) protocols can be facilitated with the message translation abilities of the DTK932V7. The DTK932V7 can be set to convert DyNet into DMX512. When setting up the DMX512 network ensure that it is connected to Port 2 of the DTK932V7 and that both ends of the DMX cable are terminated with 120 Ohm resistors.

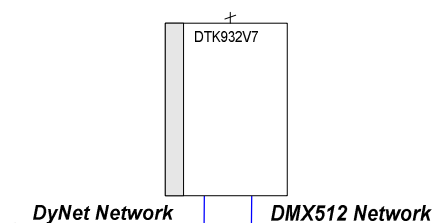

# Mounting & Supply Cable Connections

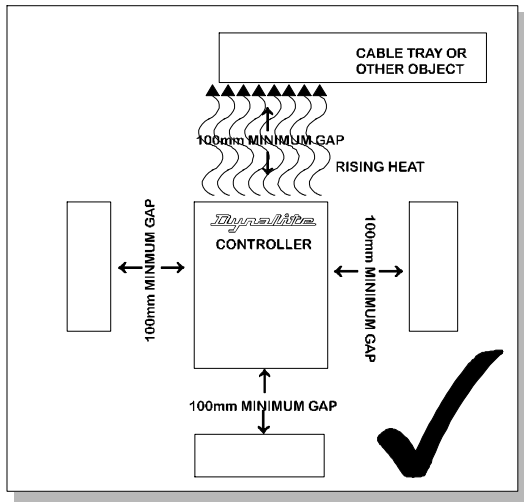

## Select A Suitable Location

This device is designed for indoor use only. If installing in an external location, the DTK932V7 must be housed in a suitable well-ventilated enclosure. Choose a dry location, that will be accessible after the installation is complete. The DTK932V7 should be mounted with an air gap of 100mm on each side and at the top and bottom of the device. This air gap is required to ensure the serviceability of the DTK932V7 without its complete removal from the mounting surface and to enable access to the service switches and LEDs.

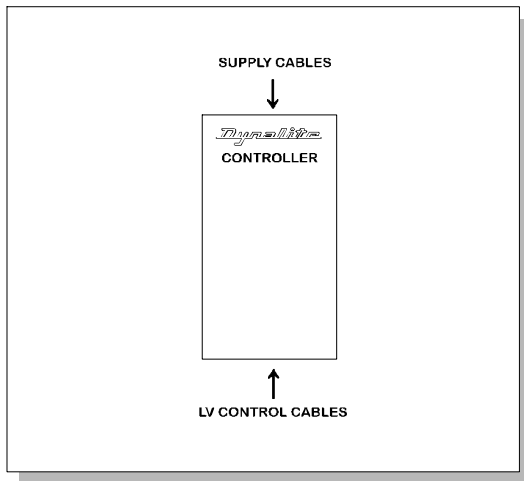

## Fixing the Device

The DTK932V7 has integral mounting brackets attached to the enclosure, designed to accommodate 4 fixing screws up to 8mm diameter. The DTK932V7 can be fixed to the wall without opening the cabinet or removing covers. Make sure no dust or other debris enters the device during installation. Do not leave the front cover off for any length of time. Excessive dust and dirt can degrade internal components.

## Allow For Cable Entry

Supply cables enter the enclosure at the top. If these cables are fed from below the mounting position, they should be routed around the enclosure to enter at the top. The control cables enter at the bottom of the enclosure. Control cables should never be run in the mains voltage sections of the enclosure.

## Supply Cable Connections

The supply terminals are located toward the centre of the enclosure and consists of Neutral, Phase and an Earth link which will accept up to two 2.5mm<sup>2</sup> cables. The supply cables should have a capacity of 0.5 Amps minimum. This device must be earthed.

# Connecting Serial Control Cables

## RJ12 Socket Connections

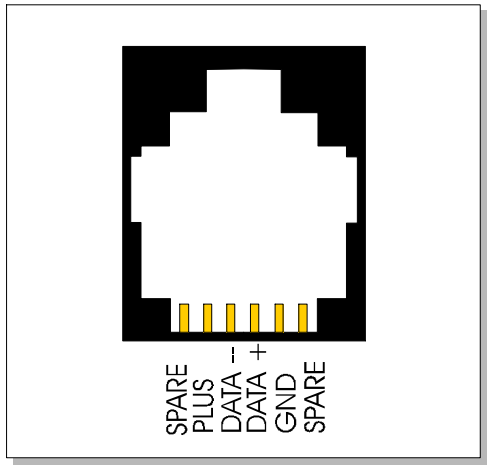

## Serial Cable Connections

There is one RS485 port for DyNet<sup>®</sup> signals, in the form of a RJ12 socket, on the front panel, which is used for the temporary connection of a PC or a Portable Programmer (DTK601). There are data terminals on the control card, for permanent connections. The recommended cable for connections to the serial port is screened, stranded RS485 data cable with three twisted pairs. Recommended cable types include:

Belden:	9503
Garland:	MCP3S
Hartland:	HCK603
M&M Cable:	B2003CS
M&M Cable:	B9503CS
Multicables:	AWM E120236 2092 20
RS Components:	368-687

One pair is paralleled for GND, one pair paralleled for +12V, and one pair used for DATA+ and DATA -.

## Recommended Cable Colour-Coding

Green/White pair	Paralleled for GND
Orange/White pair	Paralleled for +12V
Blue/White pair	Blue for DATA+
	White for DATA-

The colour-coding scheme used is not critical, as long as the same scheme is used throughout the installation.

## Serial Cable Connecting Method

The recommended connecting method is to 'daisy chain' devices (ie. starting at the first device, then looping in then out of devices, with a single cable terminating at the last device. There should not be any spurs or stubs, and only the first and last device should terminate one cable, all other devices should terminate two cables). Devices may be wired in any order. The Data Cable should be segregated from any Mains Cables by at least 300mm, or to meet local wiring rules. *A data cable that is connected to an energised dimmer is live. Do not cut or terminate live data cables.* If the Data Cable has to cross over any Mains Cables, it should do so at a 90° angle.

## Connections for the Left & Right Ports

The Left port is the preferred port for connection to Dynalite devices such as dimmers and smart panels on a spur. The Right port is the preferred port for connection to a data trunk or backbone, and third party devices such as AV controllers/touch screens and BMS. Both ports have the same connector arrangements.

## Serial Cable Permanent Connections

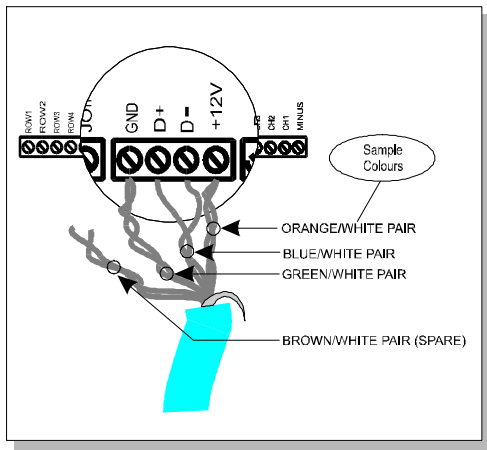

## Connect Data Cable in a "Daisy Chain"

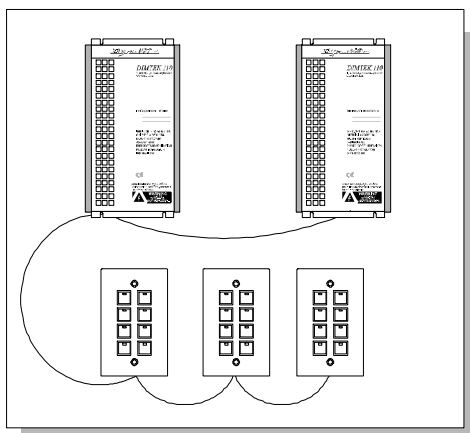

# Troubleshooting

Check the following list. If you are still unable to rectify the situation, contact your nearest Dynalite office. A complete list of distributors worldwide can be found on the Internet at: <http://dynalite-online.com/html/contacts.htm>. Please ensure that you have completed the following prior to calling our technical support department:

- Check all symptoms in the Troubleshooting list
- Check for any deviations between the installation and the installation instructions
- Make a list of the model numbers of all devices used in the system

<b>SYMPTOM</b>	<b>PROBABLE CAUSE</b>	<b>ACTION</b>
Device does not operate at all. No Service LED activity. Power supply indicator LED on PCB not lit.	Incorrect connection of Mains supply, or no power available.	Check power supply to DTK932. Check Line and Neutral input connections. Check Fuse if fitted.
Power supply indicator LED lit, but no Service LED activity.	Supply voltage too low, short circuit on network or short circuit on analogue inputs. Control PCB faulty.	Check 5V & 12V terminal voltages. Disconnect network bus and restore power. Replace control PCB.
Device appears to be operating but not passing messages.	Incorrect Dip Switch settings. Faulty LTC485 Transceiver.	Verify Dip Switch settings. Replace LTC485 Transceiver.
Device passes messages in one direction only.	Incorrect Dip Switch settings. Incorrect software configuration. Message Pass Filter incorrectly set.	Verify Dip Switch settings. Reload device & verify Message Pass Filter settings. Re compile event file.

# Hardware Controls

---

## Service Switch and LED

On each side panel of the device is a red LED (Service LED) and a small push button switch (Service switch).

## Service LED

The Service LED has 3 signalling modes, which are useful for troubleshooting:

### *Normal operation*

The Service LED should turn on and off at 50% duty approximately once per second when the dimmer is operating correctly on a “quiet” network or with no data cable connected.

### *Network activity detected*

When network activity is detected, the Service LED will blink on and off at approximately twice the normal speed for a few seconds and then revert to normal speed. This will happen even when no network cable is connected if a control panel is connected to the Control Panel Inputs as the directly connected panel actually communicates with the dimmer channels via an internal network connection.

### *Internal variable updated*

When a network message is processed which results in changes to data within the device, the Service LED will blink rapidly at approximately 5% duty for a few seconds and then revert to normal.

## Service Switch

The Service Switch, when pressed, causes a “sign-on” message to be transmitted onto the network. If the transmission is successful, the Service LED will indicate “network activity detected”. The Sign-on message contains information about the device, such as: box number, device type and embedded software version. This information is captured by DLight configuration software to speed up commissioning of large systems.

# Specifications

---

<b>Supply:</b>	230V, 50/60Hz Single Phase at 25 Watts
<b>Control Ports:</b>	2 x RS485 ports
<b>Serial Port Isolation:</b>	3.75KV optical isolation
<b>Tasks:</b>	64 plus 1 autoexec
<b>Clock:</b>	365 day with Sunrise / Sunset functions
<b>DMX512 Capabilities</b>	120 channels of DMX transmit
<b>DyNet DC Supply:</b>	750mA (approx 38 Smart Panels)
<b>Operating Environment:</b>	0° to 50°C ambient temperature 0% to 95% RH non condensing
<b>Compliance:</b>	CE, C-Tick
<b>Construction:</b>	Alloy / Steel wall mount case with epoxy finish
<b>Dimensions:</b>	Height 320mm x Width 225mm x Depth 75mm
<b>Weight:</b>	3.9 Kilograms