





**Home Automation, Inc.**

**Model 32A00-1**

**OmniTouch Touchscreen**

**Installation Manual**

**Document Number 32I00-1 Rev A  
July, 2003**

## **FCC NOTICE**

This device complies with FCC Rules Part 15. Operation is subject to the following two conditions: (1) This device may not cause harmful interference, and (2) This device must accept any interference received, including interference that may cause undesired operation.

Verified to comply with the limits of a Class B digital device pursuant to Part 15 of the FCC Rules.

## PLANNING

It is very important to plan where the OmniTouch touchscreen will be installed and the gauge/type of wire you will use for the installation. In selecting a place to mount the touchscreen, be sure to avoid an area where studs, plumbing, or electrical wiring may be located behind the wallboard. It should be mounted so that the display is at or slightly above eye level.

The touchscreen requires a minimum of 4 wires for operation (2 for power and 2 for communications). The required distance between the controller and the touchscreen will determine the wire gauge/type you should use. To prevent the touchscreen from drawing more than the specified maximum current from the controller's power supply, do not exceed the "Maximum Cable Length" based on the wire gauge/type per the table below (Table 1).

MAXIMUM CABLE LENGTH BASED ON WIRE GAUGE / TYPE				
Wire Gauge	Solid/ Stranded	Number of positive conductors	Number of ground conductors	Maximum Cable Length (feet)
24	solid	1	1	113
24	solid	2	2	227
24	solid	3	3	340
22	solid	1	1	180
22	solid	2	2	360
22	stranded	1	1	166
20	solid	1	1	287
20	stranded	1	1	267
18	solid	1	1	456
18	stranded	1	1	420
16	solid	1	1	724
16	stranded	1	1	669

**Table 1**

If cable with multiple conductors is used (such as Cat-5 cable), it is possible to connect multiple conductors together to achieve greater distance. For example, using only one of the 24 gauge conductor in the Cat-5 cable for power (1 for positive and 1 for ground), the maximum distance between the controller and the touchscreen is 113 feet. If you were to connect 2 of the 24 gauge conductors together (2 for positive and 2 for ground), the maximum distance between the controller and the touchscreen is then 227 feet. If you were to connect 3 of the 24 gauge conductors together (3 for positive and 3 for ground), the maximum distance between the controller and the touchscreen is then 340 feet.

## INSTALLATION

Hold the template (Installation Template – 32A10-1) against the wall so the top edge is at the appropriate height and parallel to the floor. Using a Punch, or similar instrument, punch through the center of each tick mark (+) on the template.

Drill a 1/4" hole at each punch mark. Using a pencil, draw a line around the quadrant of each hole as shown as shown. Carefully cut along the pencil line.

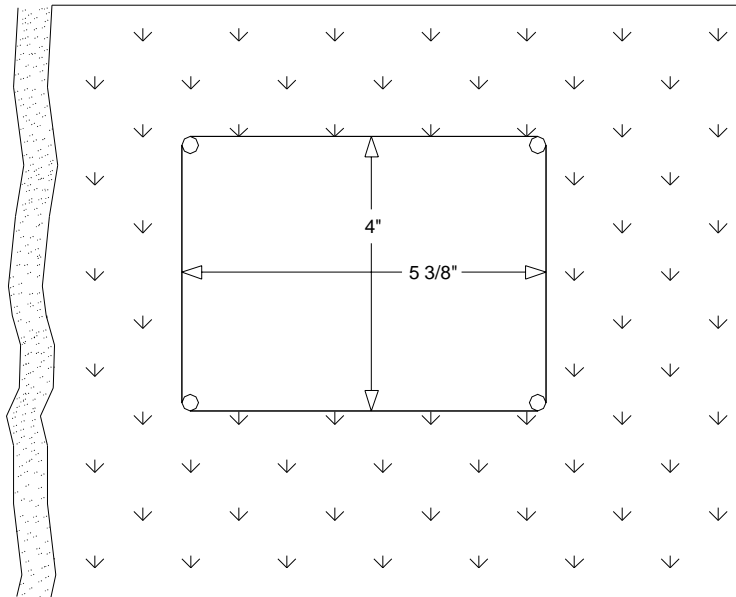

**DO NOT OVERSIZE THIS CUTOUT!**

Remove the faceplate from the touchscreen by grasping the top and bottom edges of the faceplate and carefully lifting the bottom edge away from touchscreen housing.

Run the power/communications cable (as determined by Table 1) from the controller location to touchscreen location. Attach the wires to the supplied COMM cable assembly using the supplied wire splice connectors.

Insert the COMM cable assembly through the rectangular cutout in the touchscreen backbox and plug into the mating connector (J6) on the touchscreen.

Locate the retaining flange screws in the upper left and lower right corners. Turn the screws counterclockwise until the gap between the retaining flange and the housing flange is wider than the wall.

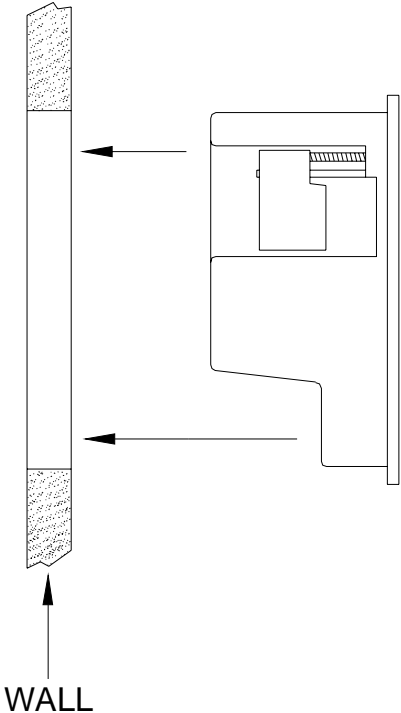

Place the assembled unit into cutout in the wall.

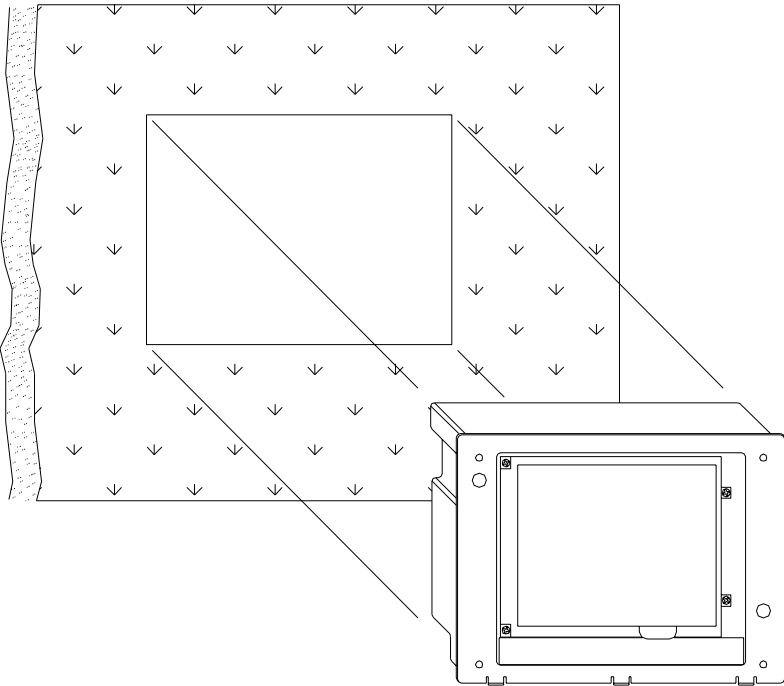

Turn the retaining flange screws clockwise until they are snug (do not over tighten).

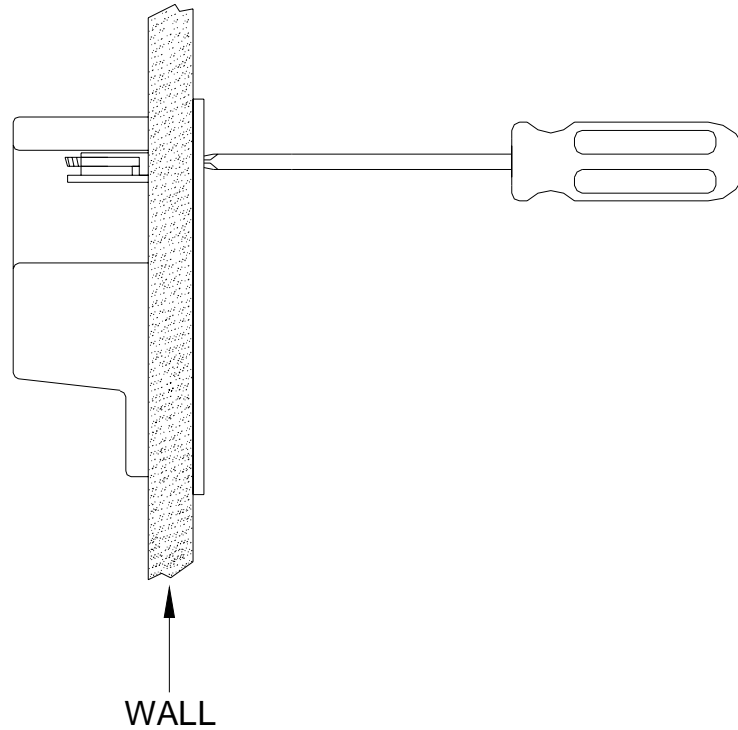

Before installing faceplate, remove the protective film from the LCD area of the touchscreen. Fasten the faceplate onto the touchscreen by hanging the top of the faceplate on the top edge of the touchscreen, then gently snapping the bottom onto the touchscreen.

## REMOVING THE TOUCHSCREEN

After installation, if it is necessary to remove the touchscreen from the wall, turn retaining flange screws 1 turn counterclockwise.

**Note:** Do not turn the retaining flange screws more than 1 full turn counterclockwise; otherwise the retaining flange may fall off into the wall.

## CONNECTING TO OMNI II / OMNIPRO II

Connect the "Yellow" and "Green" wires from the touchscreen to the "A" and "B" terminals under the section marked "CONSOLE" on the controller, respectively. Connect the "Red" and "Black" wires from the touchscreen to the "12V" and "GND" terminals under the section marked "AUXILIARY" on the controller, respectively.

A maximum combination of 8 touchscreens and consoles can be used with Omni II and a maximum combination of 16 with OmniPro II.

**NOTE: Do not exceed the maximum current limitation of the controller. If more than 2 touchscreens are used, the additional touchscreens must be powered from an external power supply.**

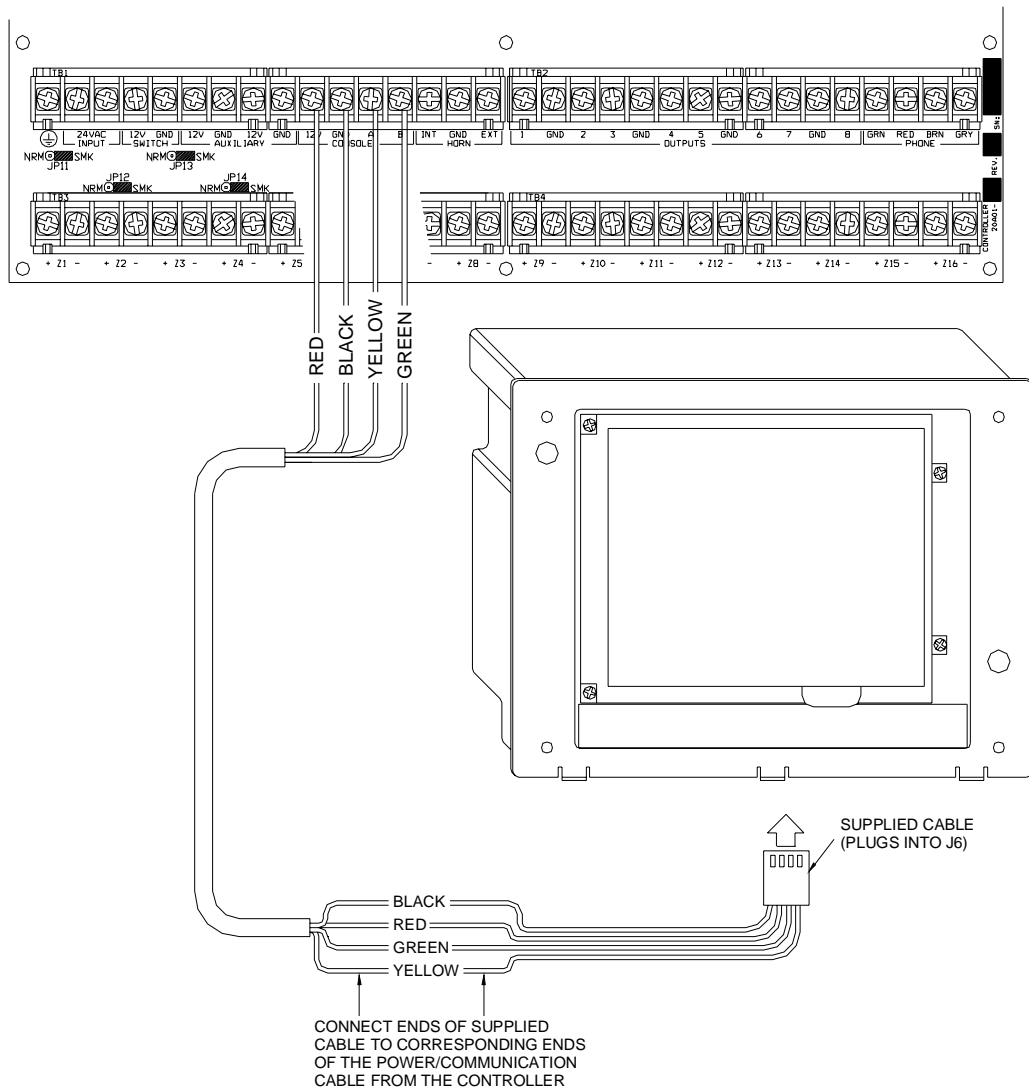

## Omni II / OmniPro II Controller Connections



## CONNECTING TO OMNILT

Connect the "Yellow" and "Green" wires from the touchscreen to the "YEL" and "GRN" terminals under the section marked "CONSOLE" on the controller, respectively. Connect the "Red" and "Black" wires from the touchscreen to the "12V" and "GND" terminals under the section marked "AUX" on the controller, respectively.

A maximum combination of 4 touchscreens and consoles can be used with OmniLT.

**NOTE: Do not exceed the maximum current limitation of the controller. If more than 1 touchscreen is used, the additional touchscreens must be powered from an external power supply.**

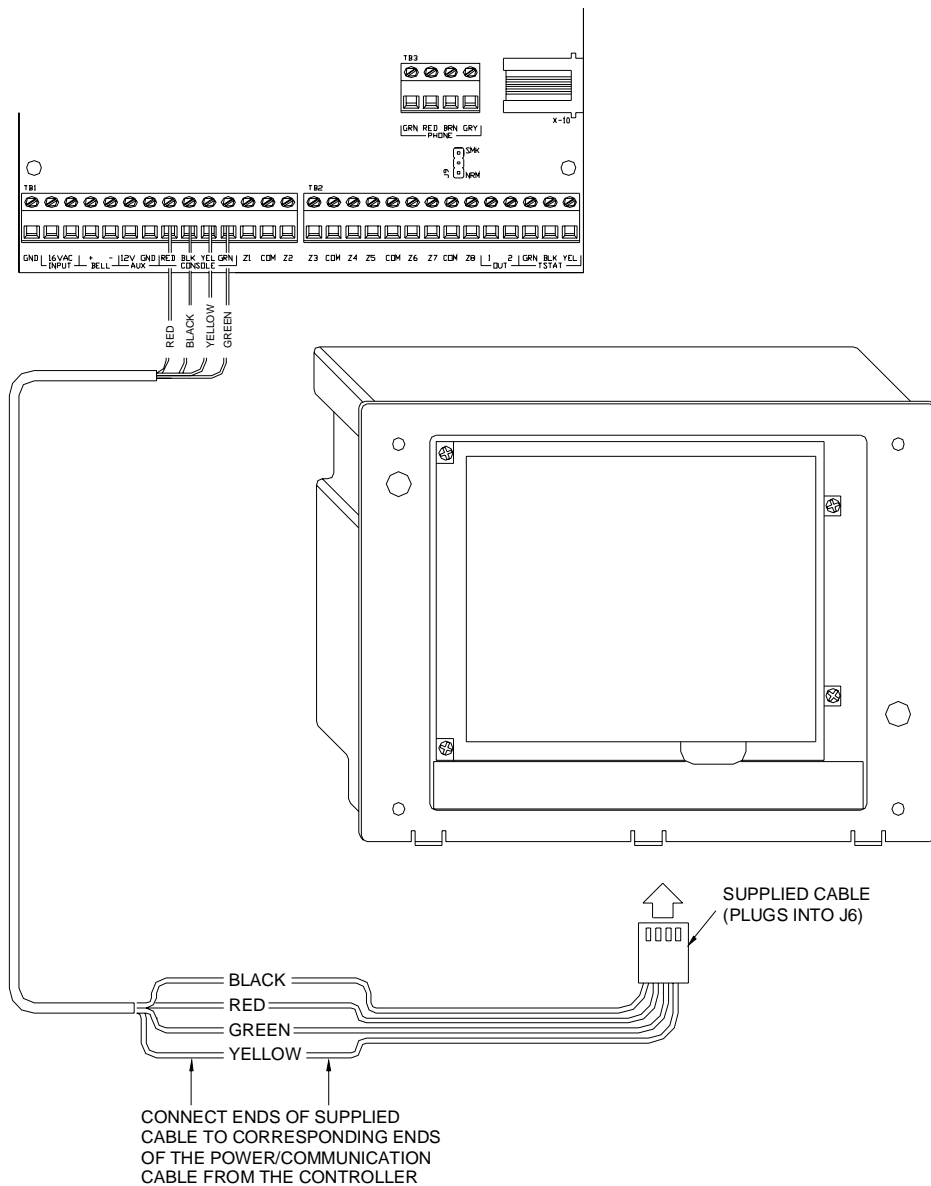

## OmniLT Controller Connections

## ADDRESSING THE TOUCHSCREEN

OmniTouch touchscreens are connected to the same communications bus as HAI consoles. Each console and touchscreen must have a unique address. The default address setting of the touchscreen is "1".

When power is first connected to the touchscreen, if the touchscreen isn't addressed properly (other consoles or touchscreens already occupy the touchscreen address) or isn't communicating with the controller, the following page is displayed.



To assign an address to the OmniTouch touchscreen, press and hold the HAI logo for three seconds. The "Touchscreen Address" page is displayed.

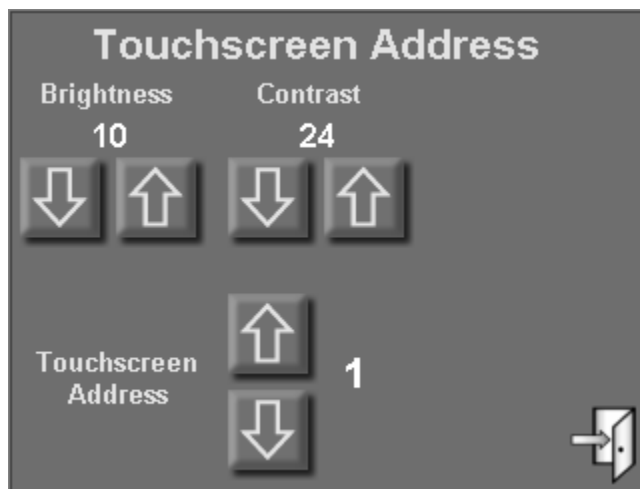

This page allows the installer to adjust the brightness and contrast of the touchscreen and assign the touchscreen address.

Press the [up arrow] button to raise the current setting and the [down arrow] button to lower the current setting. When complete, press the [exit] button in the lower-right corner to save the settings and exit.

Once the touchscreen is properly configured and communicating with the controller, other configuration items may be configured using the "Screen Setup" page. To access the "Screen Setup" page, from the Home page, touch the [Setup] icon. See the Touchscreen User's Guide (32R00-1) for additional information on these items.

**Note:** In the event of an AC Power failure and the HAI controller is running on backup battery power, the touchscreen display will be lowered to its lowest viewable setting. Do not try to adjust the "brightness" and "contrast" levels. When AC Power is restored, the touchscreen display will automatically return to its correct settings.

## **RESETTING THE TOUCHSCREEN**

If for any reason the touchscreen needed to be reset, remove the faceplate and press the reset button marked "SW1" on the circuit board below the LED.

## **SPECIFICATIONS**

Size:       Backbox cutout:  5.375" W x 4" H  
              Faceplate:   5.9" W x 4.6"H

              LCD View Area:  3.26" W x 2.47" H

Operating Voltage:    9 - 15 VDC

Maximum Current Consumption at 12 VDC:

300 mA based on Maximum Cable Length as defined in "Table 1"