



C-Bus Neo Range

Installation Instructions

5050NL Series

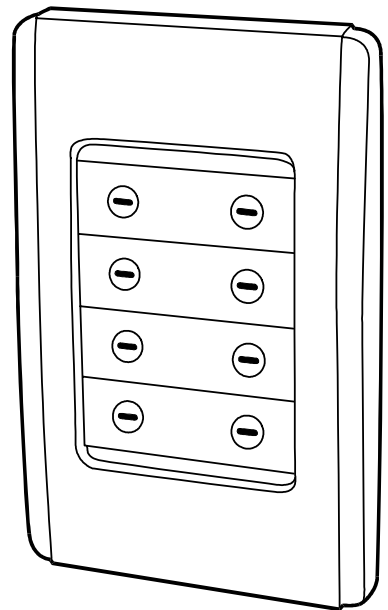
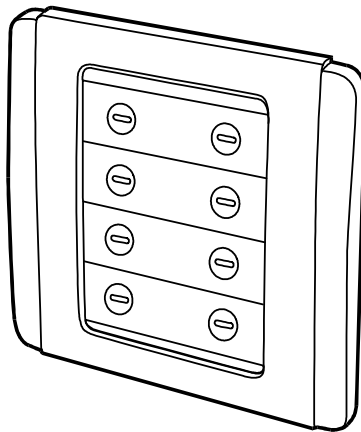

Table of Contents

Section	Page
1.0 Product Range.....	3
2.0 Description.....	3
3.0 Installation Procedure	4
3.1 Installation Location.....	4
3.2 Installing Multiple C-Bus Neo Switches, with IR Support.....	4
4.0 Mounting Instructions.....	5
4.1 Wall Box	5
4.2 Mounting Flange.....	5
5.0 C-Bus Network Connection.....	6
6.0 C-Bus Power Requirements	7
7.0 Power Surges and Short Circuit Conditions.....	7
8.0 Megger Testing.....	7
9.0 Important Notes	7
10.0 Programming Requirements	8
11.0 Important Warning	8
12.0 Unit Operation.....	8
13.0 Product Specifications	9
14.0 Standards Complied	11
15.0 Limited Warranty.....	11

Copyright Notice

© Copyright 2002 Clipsal Integrated Systems Pty Ltd. All rights reserved.

Trademarks

- Clipsal is a registered trademark of Gerard Industries Pty Ltd.
 - C-Bus and C-Bus2 are registered trademarks of Clipsal Integrated Systems Pty Ltd
 - Intelligent Building Series is a registered trademark of Clipsal Integrated Systems Pty Ltd
- All other logos and trademarks are the property of their respective owners.

Disclaimer

Clipsal Integrated Systems reserves the right to change specifications or designs described in this manual without notice and without obligation.

1.0 Product Range

5052NL	C-Bus2 One Gang Neo Key Input Unit, Rectangular Style
5054NL	C-Bus2 Two Gang Neo Key Input Unit, Rectangular Style
5058NL	C-Bus2 Four Gang Neo Key Input Unit, Rectangular Style
E5052NL	C-Bus2 One Gang Neo Key Input Unit, Square Style
E5054NL	C-Bus2 Two Gang Neo Key Input Unit, Square Style
E5058NL	C-Bus2 Four Gang Neo Key Input Unit, Square Style

2.0 Description

The C-Bus2 Neo Series Input Units are a range of high end dedicated C-Bus switches with Learn Mode capability. Units feature a multi-gang switching capacity, and facility for infrared remote controls and scene management options.

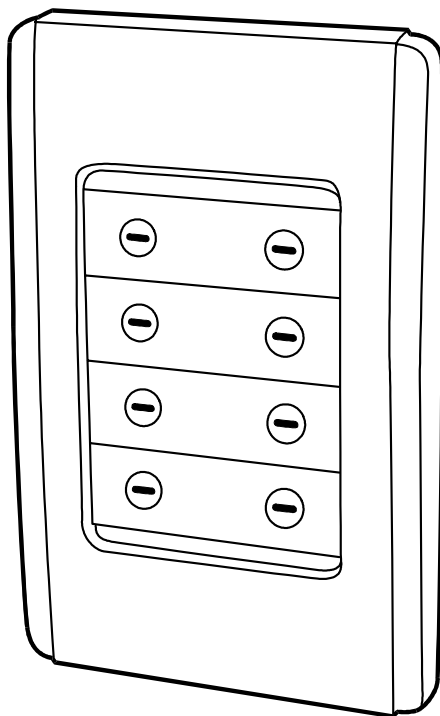

Rectangular

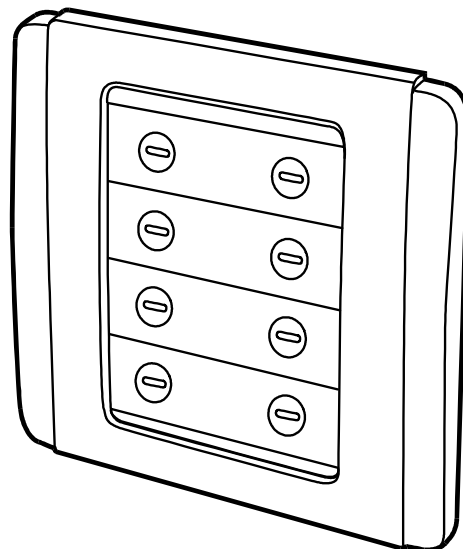

Square

C-Bus2 Neo Input Units are packed inclusive of the following items*:

- C-Bus Neo Input Unit
- Installation Instructions (this booklet)
- Warranty Statement
- C-Bus Software Coupon

Other accessories available include:

- Rocker Switch with ID Window (5052NRI)
- Wall Box (Rectangular 157/1, Square E157)
- Mounting Flange (Square 5050MF)

* Subject to change without notice

3.0 Installation Procedure

3.1 Installation Location

It is important to select the right location to install C-Bus Neo Input Units. Some considerations are listed below:

- Provide easy access to unit for switching lights and selecting scenes
- Avoid obstructions to receiving infrared signals from the Remote Control Unit
- Keep C-Bus Neo clear of places subject to water, humidity, direct sunlight or heavy dust
- Allow adequate ventilation
- Do not cover unit
- C-Bus Neo Input Units are designed for indoor use only



no wet
hand



no cleaner
spray



no
coverage

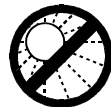

no direct
sunshine



no
dust

3.2 Installing Multiple C-Bus Neo Switches, with IR Support

Multiple C-Bus Neo Input Units can be installed on any C-Bus Network. These Units may be programmed to operate dependently or independently of each other. Care must be taken not to overlap infrared reception zones for each Unit if an infrared remote control is to be used, else both Units may trigger a scene, with unpredictable results.

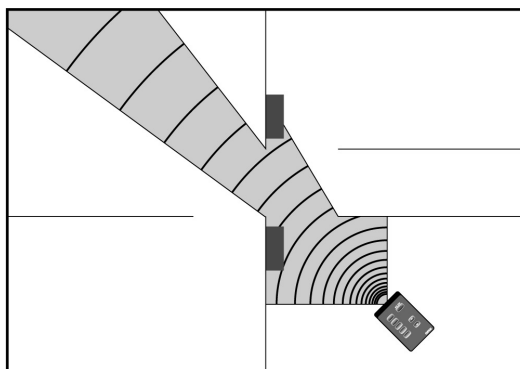

WRONG

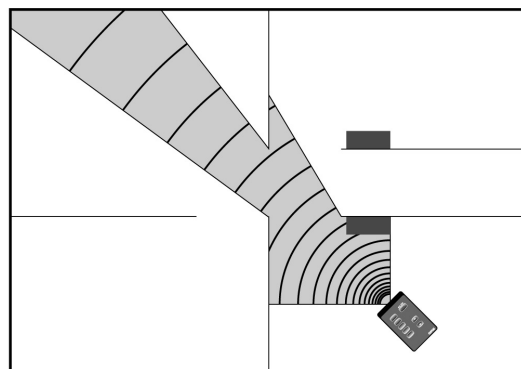

RIGHT

4.0 Mounting Instructions

There are four options for mounting the C-Bus Neo Unit. These are the following:

- Brick with Wall Box
- Timber with Wall Box
- Plasterboard with mounting flange
- Direct screwing into plugs

4.1 Wall Box

C-Bus Neo is intended to be fitted to a wall box, which allows the Unit to be easily mounted into new or existing installations. The wall box is illustrated below. This wall box may be fitted into suitably prepared masonry or attached to a noggin fitted between studs in a timber stud construction.

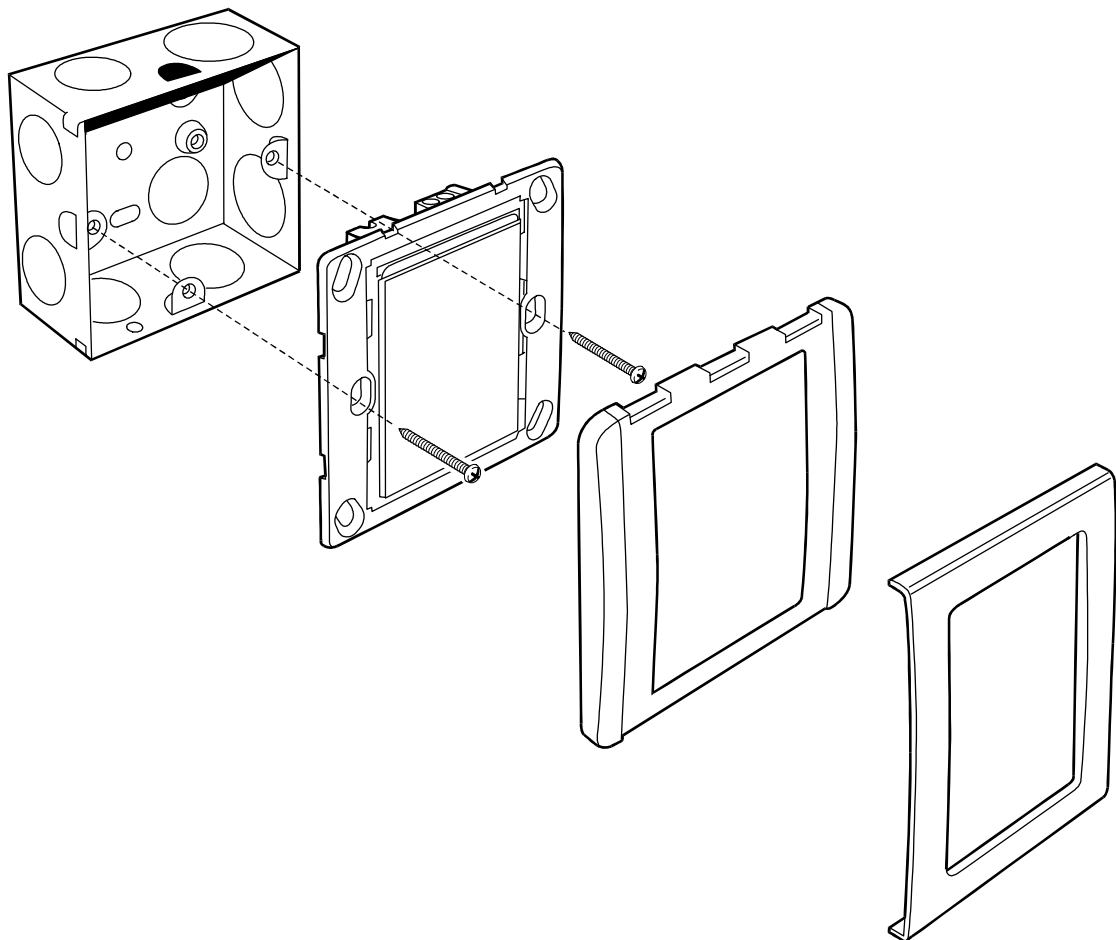

4.2 Mounting Flange

Mounting flanges are available to suit both Rectangular and Square style Neo Units. These may be used for plasterboard installations. The Square style uses a custom Mounting Flange (5050MF Neo Mounting Flange), whilst the Rectangular style is compatible with the full range of Clipsal mounting accessories (such as 154B25, 155, 155VH).

5.0 C-Bus Network Connection

Installation of C-Bus Neo on the C-Bus Network requires connection to the unshielded twisted pair C-Bus Network Cable. Connection should be made using Category 5 data cable, catalogue number 5005C305B. The C-Bus Network Connection is polarity sensitive, and is clearly marked on the rear of the C-Bus Neo Unit.

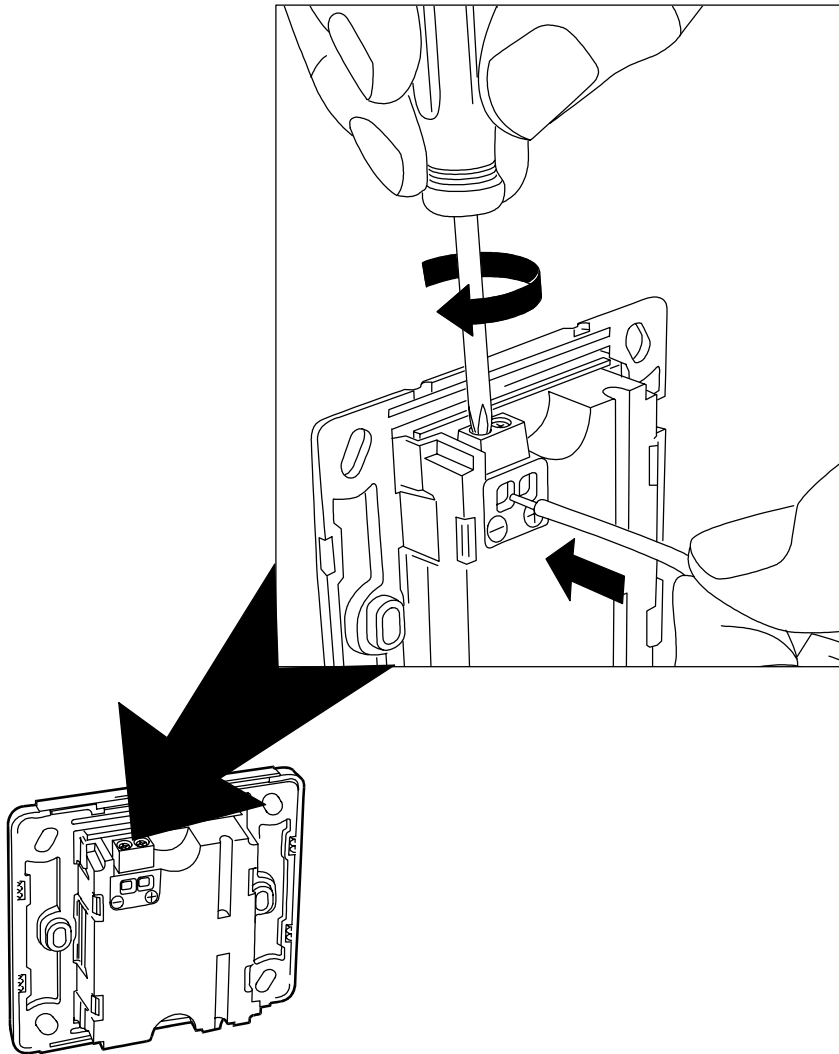

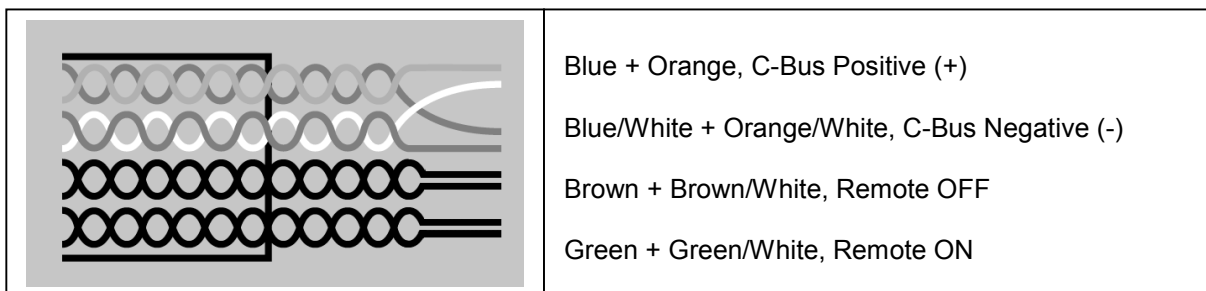

C-Bus Connection	Colour	C-Bus Neo
Remote ON	Green/White	Not Connected
Remote ON	Green	Not Connected
C-Bus Neg (-)	Orange/White	C-Bus Neg (-)
C-Bus Pos (+)	Blue	C-Bus Pos (+)
C-Bus Neg (-)	Blue/White	C-Bus Neg (-)
C-Bus Pos (+)	Orange	C-Bus Pos (+)
Remote OFF	Brown/White	Not Connected
Remote OFF	Brown	Not Connected

6.0 C-Bus Power Requirements

The C-Bus Neo Unit draws 22 mA from the C-Bus Network. Adequate C-Bus Power Supply Units must be installed to support the connected devices. If in doubt, consult the C-Bus Calculator – Network Design Verification Software Utility.

7.0 Power Surges and Short Circuit Conditions

The mains voltage must be limited to the range specified for any C-Bus Unit which is mains powered. Each Unit incorporates transient protection circuitry, however external power surge protection devices should be used to enhance system immunity to power surges. It is strongly recommended that overvoltage equipment such as the Clipsal 970 is installed at the switchboard.

8.0 Megger Testing

Megger testing of an electrical installation that has C-Bus units connected will not cause any damage to C-Bus units. Since C-Bus units contain electronic components, the installer should interpret megger readings with due regard to the nature of the circuit connection.

Megger testing must never be performed on the C-Bus data cabling or terminals as it may degrade the performance of the Network.

9.0 Important Notes

- An Electrician's Licence is not required to install C-Bus Neo Units.
- Do not connect mains to C-Bus Neo Units.

10.0 Programming Requirements

The C-Bus Neo Input Units are C-Bus2 devices. C-Bus2 is the latest generation of Clipsal C-Bus, which allows users to set relationships between Output Units and Input Units without a computer. Units may be programmed with the keys and buttons actually provided on the Units.

The source of this new functionality is the ability to assign a load, such as a light, with a controller, such as a key Input Unit, by touching the two Units one after the other. This is done while in a new mode called “Learn Mode”, so named because the C-Bus Network can now learn what the user wants to do.

Further information on the Learn Mode features may be obtained by reading the *Learn Mode Operations and Programming Guide*.

In a sophisticated installation, however, some of the basic settings created by Learn Mode may have to be overridden to create a particular effect. The C-Bus Installation Software Version 2.2.0 may be used to “fine tune” the settings if desired. The software may be downloaded from the Clipsal Integrated Systems website (www.clipsal.com/cis). A CD can be obtained by returning the enclosed Software Coupon to us at the address provided.

11.0 Important Warning

The use of any non C-Bus Software in conjunction with the hardware installation without the written consent of Clipsal Integrated Systems may void any warranties applicable to the hardware.

12.0 Unit Operation

The many powerful features of C-Bus Neo are fully described in the C-Bus Neo User’s Guide. Topics covered include:

- Basic Operation
- Switching Controls
- Dimming Controls
- Timer Controls
- Scene Selection
- Using the Remote Control

Please consult that document for further details on the operation of your C-Bus Neo Unit.

13.0 Product Specifications

Catalogue Number :	5052NL	5054NL	5058NL	≡5052NL	≡5054NL	≡5058NL
Description	C-Bus Neo Input Units, Rectangular style			C-Bus Neo Input Units, Square style		
C-Bus Supply Voltage	15-36V DC @ 22 mA required for normal operation. Does not provide current to the C-Bus Network.					
AC Input Impedance	50kΩ @ 1 kHz					
Electrical Isolation	3.75 kV RMS from C-Bus to mains (provided externally to 5050 Series Unit)					
Control Functions	Load switching, dimming, timers, scene control					
Status Indicators	User configurable Orange, Blue and Blue Nightlight					
Nightlight Option	Allows blue LED backlight illumination at low brightness level					
Warm-Up Time	5 seconds					
C-Bus Connection	One terminal block to accommodate 0.2-15 mm ² (24-16 AWG) (see section 5 in these Instructions for the pin out)					
Dimensions (L x W x H)	116 x 75 x 22mm			87 x 87 x 22mm		
Mounting Centres	84mm			60mm		
Weight	77g			67g		
Operating Temperature Range	0-45°C					
Operating Humidity Range	-10-95% R.H.					
Colour Options	Various					

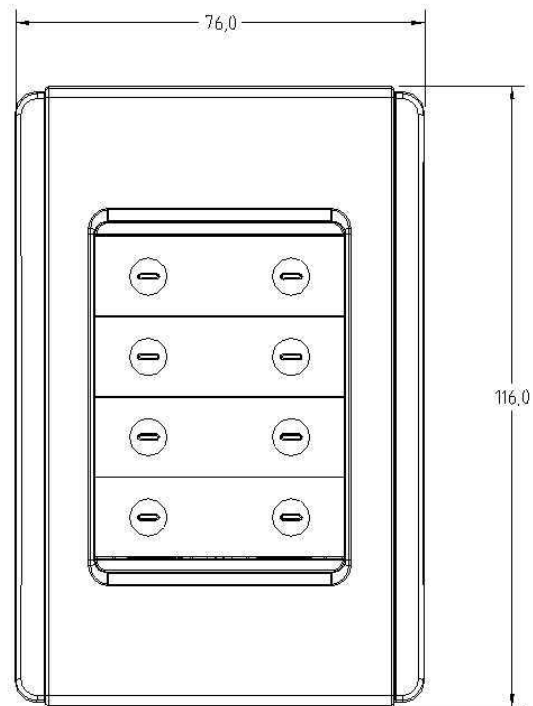
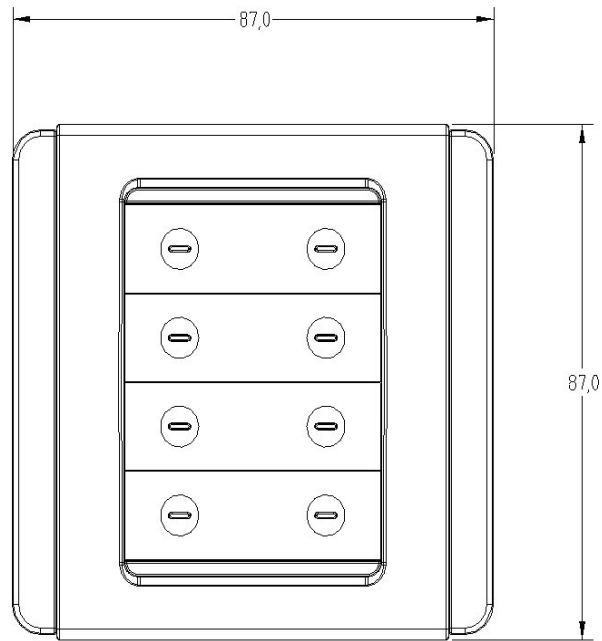

All dimensions in mm.
No user serviceable parts inside.

14.0 Standards Complied

Standard	Title
AS/NZS 3100:1997 inc Amd. 5	General Requirements for Electrical Equipment
AS/NZS 3108:1994 inc Amd. 6	Requirements for Safety Extra Low Voltage
IEC 742:1983 Amdt (1) IEC 60742 Am1 Ed 1.0b 1983 (Am 1992).	Isolating transformers and safety isolating transformers - Requirements
AS/NZS 1044:1995 EN 55014-1:1993 CISPR 14:1993	Electrical motor-operated and thermal appliances for household and similar purposes
EN60669-2-1:1996	Immunity and emissions for electronic switches
EN 61000-3-2:1995 A1, A2 IEC 61000-3-2:1995 A1, A2	Harmonic Current Emissions Standard
EN 61000-3-3:1995 IEC 61000-3-3: 1995	Voltage Fluctuations and Flicker Standard
EN 61000-4-2 IEC 61000-4-2	Immunity to Electrostatic Discharge Basic Standard
EN 61000-4-3 IEC 61000-4-3	Immunity to Radio Frequency Electromagnetic Field Basic Standard
EN 61000-4-4 IEC 61000-4-4	Immunity to Electrical Fast Transients Basic Standard
EN 61000-4-5 IEC 61000-4-5	Immunity to Electrical Surges Basic Standard
BS/EN 61000-4-6	Continuous Radiofrequency emissions
89/336/EEC	European Union Directive on Electromagnetic Compatibility

15.0 Limited Warranty

The C-Bus Neo product carries a two year warranty against manufacturing defects (refer to Warranty Statement).

Further Information

For further information about programming and configuring C-Bus Neo Input Units, please consult the documentation supplied with the C-Bus Installation Software (the latter three documents are provided in electronic format on the distribution disk (Portable Document File [PDF] and requires Adobe Acrobat Reader v4.0 or higher to view or print):

- **C-Bus Neo Installation Instructions**

The printed booklet you are reading now contains detailed information for the installer regarding Unit mounting, wiring, and C-Bus Network requirements. C-Bus Neo features and specifications are also presented.

- **C-Bus Neo User's Guide**

The C-Bus Neo User's Guide contains information about C-Bus Neo operation, general care and use instructions.

- **C-Bus Neo Programming Reference**

The C-Bus Neo Programming Reference presents a comprehensive guide to programming requirements and advanced capabilities of C-Bus Neo.

- **C-Bus Learn Mode Operations and Programming Guide**

The C-Bus Learn Mode Operations and Programming Guide presents a comprehensive guide to C-Bus Learn Mode and gives full details of this mode.

- **Technical Support and Troubleshooting**

For further assistance in using C-Bus Neo, please consult your nearest Clipsal Integrated Systems Sales Representative or Technical Support Officer.

Technical Support Hotline

[1 300 722 247](tel:1300722247)

(Cost 25¢ a call, Australia Only)

Technical Support E-mail

techsupport.cis@clipsal.com.au

Sales Support Email

sales.cis@clipsal.com.au

Clipsal Integrated Systems Website

clipsal.com/cis

Products of Clipsal Integrated Systems Pty Ltd

ABN 15 089 444 931

Head Office

12 Park Terrace, Bowden

South Australia 5007

International Phone [+61 8 8269 0560](tel:+61882690560)

International Fax [+61 8 8346 0845](tel:+61883460845)

Internet clipsal.com/cis

E-Mail cis@clipsal.com.au

1036307