

Concept: Hotelier
Category: Hotel Control Devices

Smart-Hotel DLP Panel

Bedside or Table side Smart Hotel DLP



Description

Smart-Hotel DLP Switch Panel (Chameleon)

An Extremely Easy to use full life-style elegant combined panel that solve the problem of cluttering and wall agony, the problem of knowing buttons functionality, and the problem of matching the decoration finishes and materials. It is an Award Winner.

Comes with Built-in Temperature Sensor, HVAC Control, Music, TV/DVD, Lighting, Shades, and Services

- Changeable Screen Functions
- Changeable Language from Hotel Management software for all clients nationality
- Changeable Buttons Colors
- Changeable Face Cover Plate
- Screw less Mechanism Mounting
- Infra Red Remote Controlled Panel with LED and LCD Back Lighting

CEA—Best Energy Saving Product Category

Available Accessories

- GI Back Box: 3"X3"X 1.5"-2"
- Black Glass Cover Plate
- White Glass Cover Plate
- Silver Aluminum Cover Plate
- Yellow or Red Golden Cover Page
- Wood / Marble / Special Coffee Cover Plate
- US Standard Cover Plate

Page Related To

Model #	HDL Part #
SB-DLP5-GRMS	DLP5-GRMS

Features	Specifications
<ul style="list-style-type: none"> • LCD Back Lighting with Time Out Flexibility • Buttons LED Backlighting • Single Click, Double Click, Continuous Press with Different Functions for each Button. • Each Button: Right and Left different or similar operation option flexibility • Total of 5 Pages each of 4 Buttons and 2 Momentary switches = 40 Gang in one 3X3 in Switch.. • Graphical and Text Display for easy Usage of New users • Support all Languages in the world. • Built-in Temperature Sensor for Room Real Time Temp. • Ability to Calibrate Temp+- • Infra Red Receiver • Flexible Finishes available as Stainless, Golden, Glass, Wood, marble ++ • LCD Size 5.00 cm X 2.75 cm • Screw Less Mounting Using Advanced Magnet Attachment Idea • Changeable Button Colors • Real Time Clock and room Temp. Displaying 	<p>Power Input: 8-32V DC; By BUS</p> <p>Power Consumption: 25mA/DC24V</p> <p>Ambient Conditions: Working Temperature: 0°C - 45°C</p> <p>Working Relative Humidity: 20% - 90%</p> <p>Storage Temperature: -40°C - +55°C</p> <p>Storage Relative Humidity: 10% - 93%</p> <p>Pages: 5 Pages Dynamic</p> <p>Languages: Multi-Lingual</p> <p>LCD Brightness: Controlled Digitally 10% - 100% + Back Light Off after Time Out, Wake Up ++</p> <p>Interface: LCD display, 5 Double pushbuttons.</p> <p>Installation: Wall mounting into European British, *US Standard Back Box</p> <p>Mounting: 2 Strong Magnets for Easy and Elegant Screw Less Installation and Programming</p> <p>Graphics: Bmp and Text</p> <p>Communication: Smart-BUS + IR</p> <p>Addressing: MAC & Digital</p>



Applications

- Hotel Guest Room
- Ball and Meeting Room
- Hotel Restaurants

Dimensions

Front: 8.5cmX8.5cm
Depth: 3.5 cm

Brief Specification

40 gang DLP LCD Panel, with Temperature Sensor, Multilingual and Graphics, IR Remote Controlled

Required With

Use 8 – 32V DC Power supply
25mA/DC24V

Pre-Requisite

Any S-Bus System,
or any H-Net System

Wiring Instruction

Daisy Chain, Bus Wiring Topology, Use Cat5e Twisted

Connection Diagrams and Engineering Schematics

DLP LCD Panel	Model #	HDL Part #
Bedside or Table side Smart Hotel DLP	SB-DLP5-GRMS	DLP5-GRMS

Product Details and Sizes

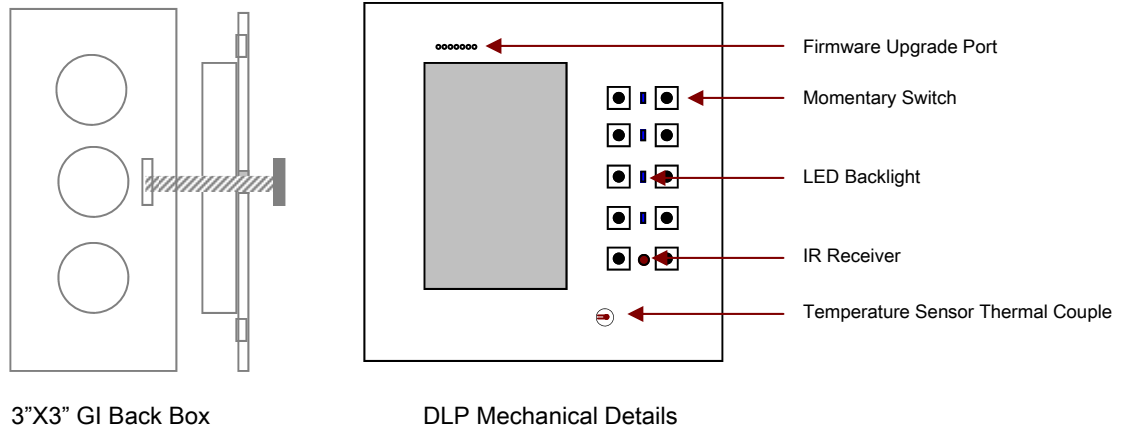
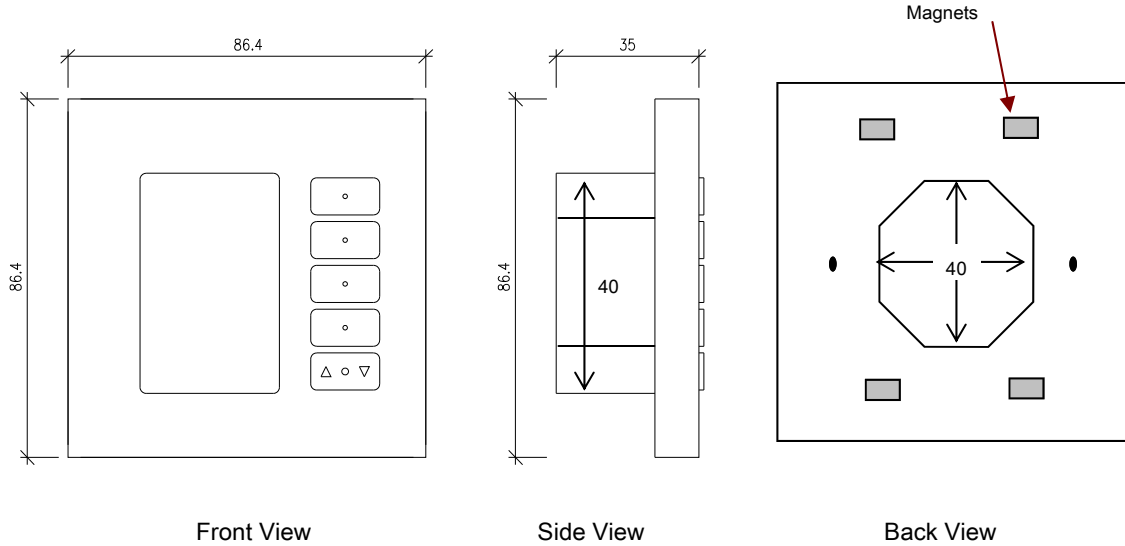

Graphics File	Net Weight	Box Size	Gross Weight
BMP: For Each Button 80WX32H Pixels	200 grams	10X10X5 cm	230 grams

Connection Diagram

